



# Xenon Net

100

Collection of swivel chairs with mesh back designed by German ITO Design studio. Thanks to innovative lumbar support and the possibility of individual modifications, the Xenon Net chair enables you to sit comfortably and adapt to your body shape.

## Collection features:

---

- innovative depth adjustment of the lumbar support (SmartADLS)
- mechanisms synchro with smooth and quick adjustment of backrest spring strength
- graphite J-bar, connecting backrest, seat and mechanism
- available with high and low backrest, version with headrest and jacket hanger
- option available in full upholstery
- conference version - legs or cantilever and version with or without armrest
- Blue Angel certificate - confirms that our chair is environmentally friendly

## Technical specifications:

---

product versions

- 100S - high mesh backrest, Synchro mechanism,
- 100SL - high mesh backrest, Synchro mechanism, sliding seat
- 100SFL - high mesh backrest, Synchro mechanism, sliding seat, seat and backrest forward tilt

### mechanism

- Synchro S - adjustment of seat height, synchronising mechanism with the possibility to adjust the resilience of the backrest to the weight of the sitting person. The synchro mechanism can be locked in one of five positions.
- Synchro SL - S mechanism with function of sliding seat. The synchro mechanism can be locked in one of five positions.
- Synchro SFL - SL mechanism with function of additional seat / backrest tilt The synchro mechanism can be locked in one of four positions.

### base

Five-star base.

Variants:

- chrome (polished aluminium)
- black (plastic)

### armrests

- P59PU - Height adjustable armrest (range 80 mm), sliding pad (+/- 50 mm) with span option (+/- 30 mm). Colour of armrest frame: black.
- P61PU - Height adjustable armrest (range 80 mm). Colour of armrest frame: black.

**gas lift**

option - Lumbar support - height adjustable

**Castors / glides**

- option - Hard castors - for soft floors (set)
- option - Soft castors - for hard floors (set)
- option - Teflon glides - universal (set)

**seat**

Black plastic cover; deciduous plywood; cold molded foam - density 65 kg/m3.

**backrest**

Back frame made of polypropylene. Black color.

Types of backrest mesh:

- RUNNER - black
- STRING - black and grey

Hanger, maximum load 4 kg.

SmartADLS - patented solution and a unique feature of the Xenon collection ensuring proper support of the lower spine.

J-bar (backrest bracket) - always in grey colour.

**net weight**

100S /SL/SFL - 101S/SL/SFL - 18,5 kg

**gross weight**

100S /SL/SFL - 101S/SL/SFL - 21,5 kg

**Product dimensions:**

---

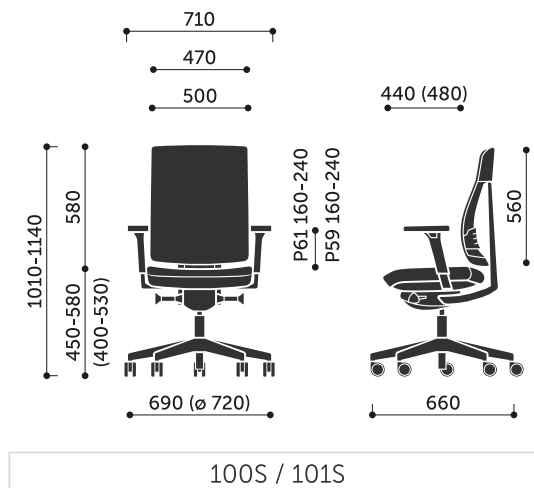

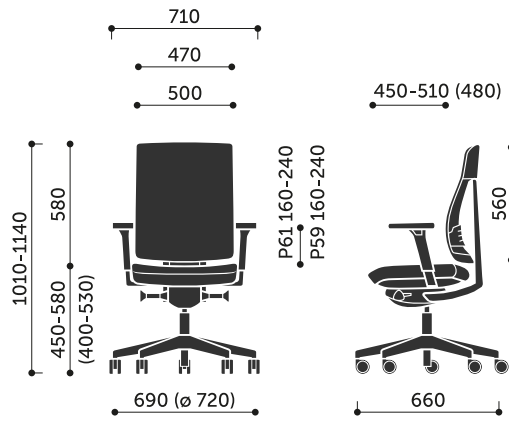

100SL / 101SL / 100SFL / 101SFL

**Dimensions of other models in the collection:**

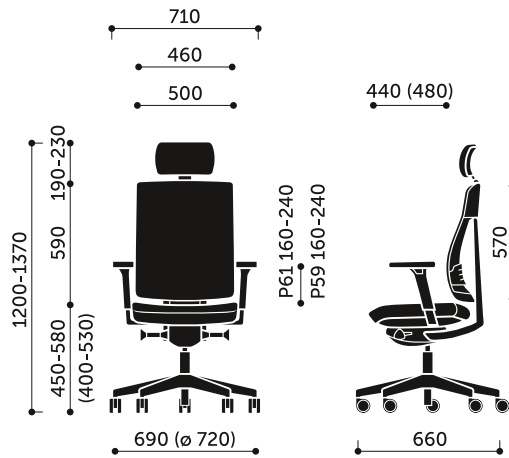

110S / 111S

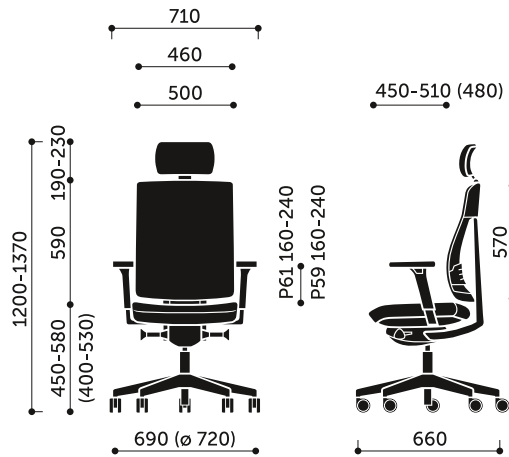

110SL / 110SFL / 111SL / 111SFL

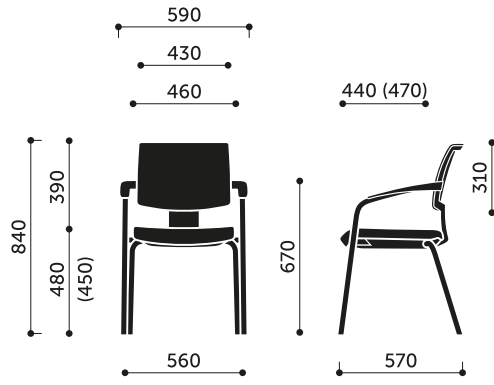

20H 2P

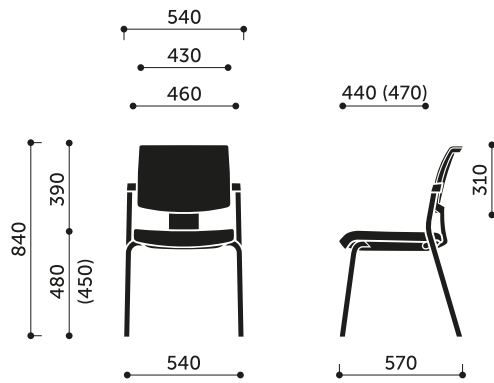

20H

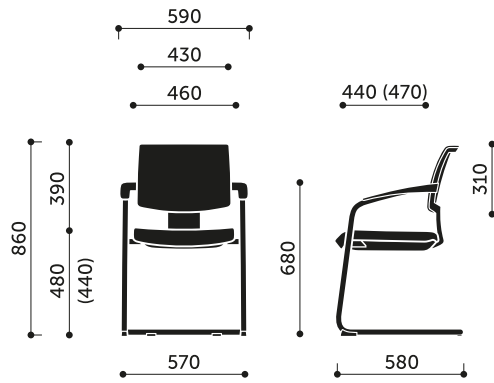

20V 2P / 20VN 2P

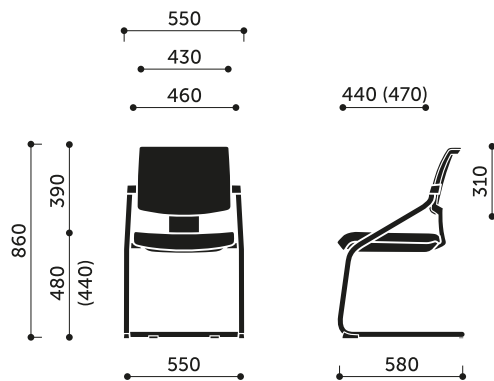

20V / 20VN

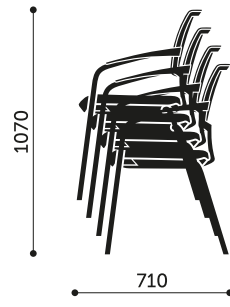

H

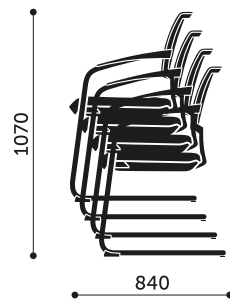

V